

# Proprietary LoRa Receivers

## Modbus Receiver - TCP/IP & RTU

RX MODBUS 500-302



- ✓ Can handle 50 Enless sensors
- ✓ Converts received data into Modbus table
- ✓ TCP/IP and RTU communication
- ✓ Facilitates integration of Enless sensors into the BMS
- ✓ Power supply 7.5 - 24VDC

### Technical Specifications

Physical Characteristics	
Protection rating	IP60
Mounting	Wall / Clamp / DIN Rail
Operating temperature	-20 / +55°C
Power supply	External 7.5 to 24VDC (typ. 12V 1A)
Radio	
Radio antenna	Antenna not provided (SMA connector) Use of ANT REN SMA LR 1000-008 antenna recommended
Supported protocol	Enless proprietary LoRa
Frequency	868MHz

## Configuration

Receiver server	Pairing of sensors Analysis of RSSI levels Visualization of Modbus table
Modbus	Possible configuration of sensors from the receiver's Modbus table

## Communication with the BMS

### Modbus

Connection	TCP/IP or RTU RS485 / RS232
TCP client	One TCP client at a time

## Certifications



## Dimensions (mm)

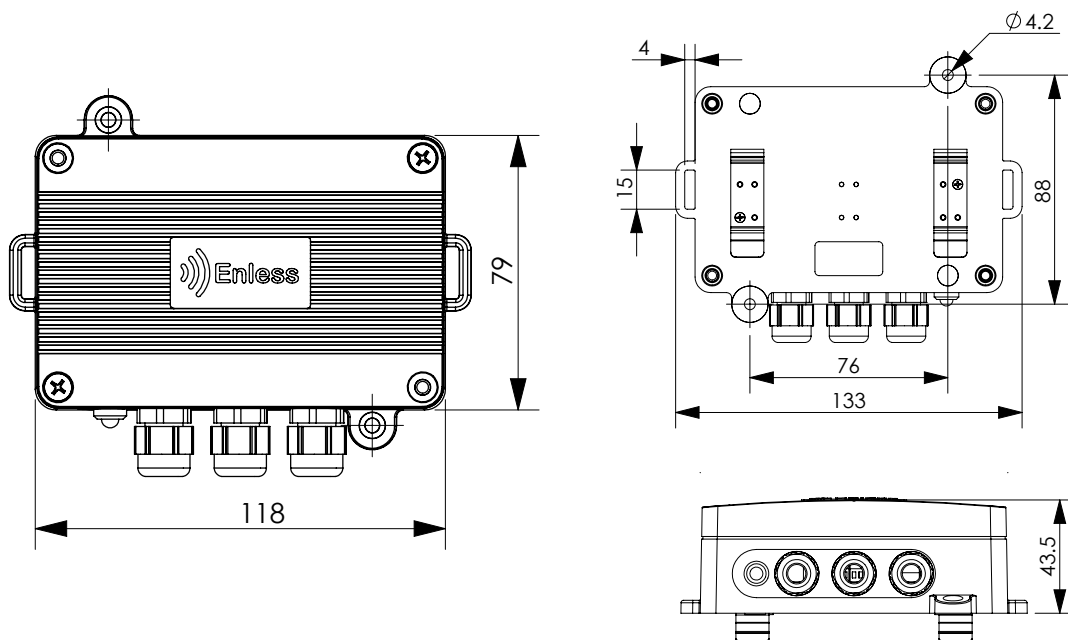

DTM56-g